



# 2026

## EQUIPMENT CATALOG

Effective January 1, 2026





# SMART SOLSTICE FEATURES

NOW AVAILABLE ON COLD ZONE FRYERS

## **AUTOMATIC FILTRATION**

Filter at the press of a button! No doors to open or levers to pull. Increase safety and reduce labor time.

## **AUTOMATIC OIL TOP OFF**

Keep your oil at optimal depth at all times! Auto top off replenishes oxidizing oil with fresh oil as needed.

## **SMART PUMP AND DRAIN**

Increased width 3" drain and 10gpm pump reduces filter cycle time by up to 25%.

## **POWERED WASTE AND FRESH OIL MANAGEMENT**

Effortless oil fills and dumps with automatic input and output connections to third party oil systems.

## **JUG IN BOX (JIB) MANAGEMENT**

Sensors detect "JIB" oil levels and warn operators when oil dips below 20%.

## **SmartOIL SENSOR**

The sensor reads the properties of the oil during a filter cycle. This data allows the user to know exactly when to re-use oil and when it's time for a change. SOS works smarter to increase your oil life!

## **CONTROL UPGRADE**

10.1" Open Kitchen enabled OneTouch screen with automatic tracking and filter data functions.

EXTEND  
OIL LIFE

INCREASE  
PRODUCTION

SAVE  
TIME AND  
LABOR

Features available on all SSH55, SSH60, SSH60W and SSH75 models.

Oil absorption may vary depending upon oil type, product type and cooking temperature.

# Thinking of Switching to **Solid Shortening?**

Pitco fryers are adaptable to many types of shortening, both liquid and solid.

## **CONTROL SYSTEM**

It's important to bring solid shortening up to heat gradually through a Melt Cycle. Melt Cycles are programmable through solid state, digital, computer and [OneTouch controls](#). On a touch screen, choose the "Solid" option under Equipment Settings > General > [Melt Cycle](#).

## **HEAT TAPE**

Pitco offers several options for waste oil handling. [Heat tape](#) is used internally for use with solid shortening. Additional heat tape charges apply in cases of solid shortening.

## **TOOLS AND ACCESSORIES**

Solid shortening can harden when cooled. Use of a [clean out rod](#) is important in cases where cooled solid shortening may clog drain pipes.

## **STAY SAFE**

As always, wear heat resistant gloves when working with any type of hot shortening. Adjust oil levels as needed.



# TABLE OF CONTENTS

Fryer Control Options \_\_\_\_\_ 1-2

## ROV (REDUCED OIL VOLUME) FRYERS

SELVRF/SGLVRF \_\_\_\_\_ 4  
SSHLV/SELV \_\_\_\_\_ 6

## GAS FRYERS

(ROV) Reduced Oil Volume Fryers \_\_\_\_\_ 6-7  
Solstice High Efficiency Supreme Series \_\_\_\_\_ 9  
Solstice Gas Fryers \_\_\_\_\_ 14  
Solstice Supreme Gas Fryer Systems \_\_\_\_\_ 15  
Solstice Gas Fryer Systems \_\_\_\_\_ 17  
Economy Gas Fryers \_\_\_\_\_ 19  
Standard Solstice Gas Fryers \_\_\_\_\_ 19  
Countertop Gas Fryer \_\_\_\_\_ 19  
Energy Star Gas Fryers \_\_\_\_\_ 19  
MEGAFRY - High Volume, High Efficiency \_\_\_\_\_ 20  
Flat Bottom Fryers \_\_\_\_\_ 21  
Solstice Filter Drawer Filtration System \_\_\_\_\_ 22  
Crisp'N Hold \_\_\_\_\_ 23

## ELECTRIC FRYERS

(ROV) Reduced Oil Volume Rack Fryers \_\_\_\_\_ 4  
(ROV) Reduced Oil Volume Fryers \_\_\_\_\_ 6-7  
Solstice Electric Fryers \_\_\_\_\_ 12  
Solstice Electric Fryer Systems \_\_\_\_\_ 16  
Energy Star Electric Fryer \_\_\_\_\_ 19  
Solstice Filter Drawer Filtration System \_\_\_\_\_ 23  
Holding & Merchandising \_\_\_\_\_ 24

## PREPACKAGED FILTRATION SYSTEMS

Prepackaged SSH Fryer Systems with Filtration \_\_\_\_\_ 15  
Prepackaged SE Fryer Systems with Filtration \_\_\_\_\_ 16  
Prepackaged SG Fryer Systems with Filtration \_\_\_\_\_ 17

## FILTRATION SYSTEMS & OIL HANDLING

Integrated Oil Management Systems \_\_\_\_\_ 22-23  
Portable Filtration \_\_\_\_\_ 22  
Fat Vat \_\_\_\_\_ 22  
Solstice Filter Drawer Filtration System,  
SG, SSH, SE, FBG, SGM \_\_\_\_\_ 23

## WATER COOKERS

Solstice Rethermalizer - Gas, Electric and Counter Top \_\_\_\_\_ 26  
Pasta Cookers - Solstice Supreme Gas \_\_\_\_\_ 27  
Pasta Cookers - Solstice Supreme Electric \_\_\_\_\_ 27

## OPTIONS & ACCESSORIES

Flexible Connectors, Cleaning Accessories,  
Filter Accessories, Filter Paper \_\_\_\_\_ 28  
Institutional Packages \_\_\_\_\_ 28  
Tank Covers, Casters, Dump Stations \_\_\_\_\_ 29  
Splash Guards & Work Shelves \_\_\_\_\_ 29  
Basket and Wire Goods \_\_\_\_\_ 30-31

## WARRANTY

Extended Warranty \_\_\_\_\_ 32  
Original Economy Equipment Limited Warranty \_\_\_\_\_ 33-34

## FIND A REP

Sales Reps \_\_\_\_\_ 35-36

## ORDERING INFORMATION

Ordering Information \_\_\_\_\_ 37  
Returns & International Orders \_\_\_\_\_ 37

## CONTACT US

[P] +1 603.225.6684 | [F] +1 603.225.8472

[www.pitco.com](http://www.pitco.com)

Orders: [orderpitco@pitco.com](mailto:orderpitco@pitco.com)

Administrative Office: 553 Route 3A | Bow, NH 03304

Mail: P. O. Box 501 | Concord, NH 03302

Freight: 39 Sheep Davis Rd | Pembroke, NH 03275

\*\* PRICES AND SPECIFICATIONS SUBJECT TO CHANGE WITHOUT NOTICE \*\*

 CE approvals for individual models may not be available with all options or in all areas. Consult the factory for more information.

[P] +1 603.225.6684 | [www.pitco.com](http://www.pitco.com)



# FRYER CONTROL OPTIONS

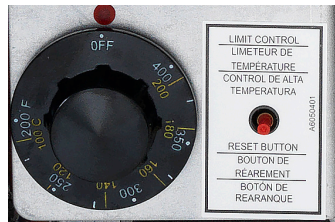

## MILLIVOLT CONTROL

- Manual pilot ignition
- No power required for operation



## SOLID STATE CONTROL - Available with Matchless Ignition

- Greater Temperature Control - plus or minus 1°F reactivity from set temperature
- Better recovery, increased production
- Melt Cycle
- Boil Out
- Back up option allows the Solid State control to function as a back up to the Digital Controller, 12 Button, MultiZone or Profile Computer Control

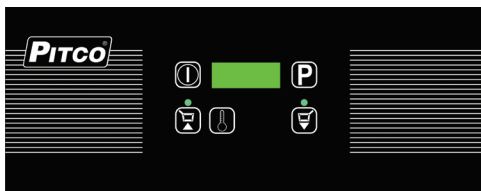

## DIGITAL CONTROL - Available with Matchless Ignition

- Greater Temperature Control - plus or minus 1°F reactivity from set temperature
- Better recovery, increased production
- Melt Cycle
- Countdown timer with alarm
- Cook time and temperature setting
- Ease of use "touch on/touch off" - 2 product buttons
- Solid State Control (above) can be added as a backup control

## 12 BUTTON COMPUTER CONTROL - Available with Matchless Ignition

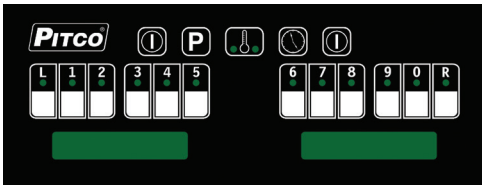

- Greater Temperature Control - plus or minus 1°F reactivity from set temperature
- Better recovery, increased production
- Melt Cycle
- Ease of Use: 12 product buttons
- Programmable temperature, cook, shake, and hold functions; volume levels
- Anti-boil over mode - prevents damage to controls during this procedure
- Consistent Product - elastic time
- “Lifeguard” system limits cycling of fryer controls to prolong fryer component life
- Instant On - Controller calls for heat as soon as a timer is activated instead of waiting for the temperature drop.
- Solid State Control (above) can be added as a backup control

## MULTI-ZONE COMPUTER CONTROL

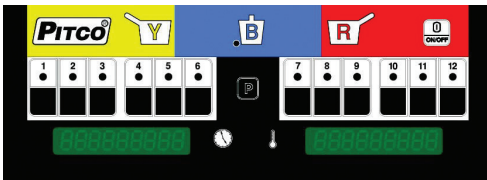

All the features of the 12 Button plus:

- Perfect for 3 basket configuration
- Simple two step process: Select product, then select zone
- Different color zone for each basket
- Eliminates confusion of which product started cooking first
- Solid State Control (above) can be added as a backup control

## PROFILE COMPUTER CONTROL

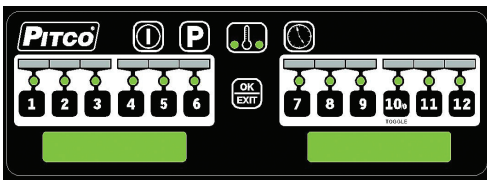

All the features of the 12 button control plus:

- The ability to set multiple temperature profiles
- Change temperatures automatically during the cook cycle for the perfect quality product
- Solid State Control (above) can be added as a backup control
- Menu strip windows for product button identification

# OneTouch

## THE EASY TO USE ADVANCED CONTROLLER FOR YOUR FRYER

Language support for your locations across the nation & around the globe, store your recipes & product cook times on your fryer for the right taste every time.

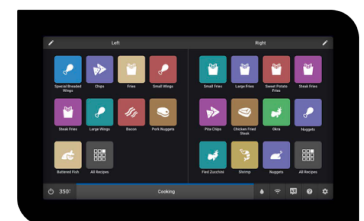
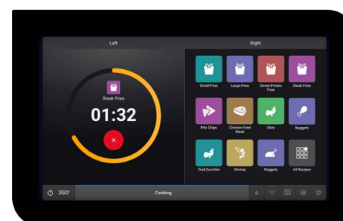
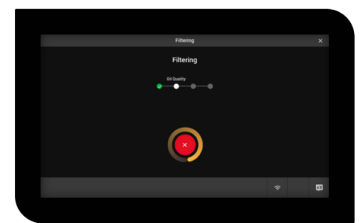
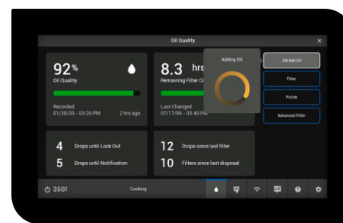
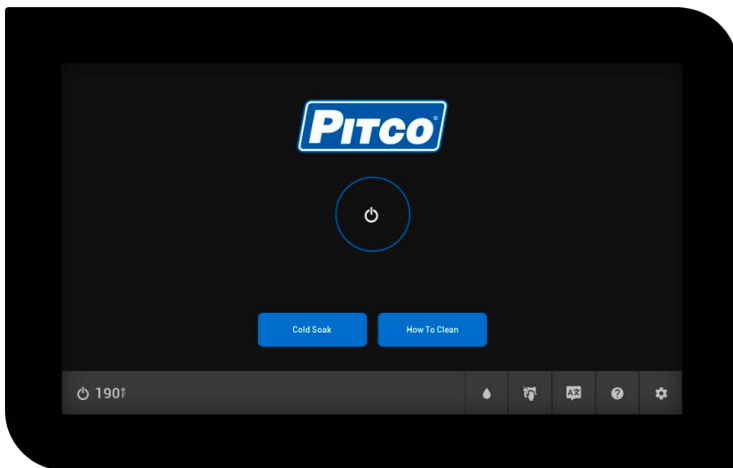

### 10.1" hui OneTouch Screen

- On-screen brand logo
- Brightness adjustment
- Product key graphics
- USB port for data transfer

### Data Tracking

- Hours of operation
- Cook cycles
- Filter cycles

## SOLSTICE SUPREME ROV REDUCED OIL VOLUME

## REDUCED OIL VOLUME RACK FRYER GAS & ELECTRIC

### AUTOMATIC RACK LIFTS AVAILABLE AS ADD-ON, MANUAL RACKS COME STANDARD

- Auto Top Off (ATO) is standard and included
- Reduce operating costs
- Increase safety for operators who directly handle fresh/waste oil
- Reduces carbon footprint:
  - Less processed oil from first fill
  - Fewer deliveries or waste pickups
  - Better for the workplace
- Maintain high production
- 76lbs. of oil, 15lbs. oil reserve
- Longer oil life
- 10 Gallon/minute filter pump
- 1.5" Oil drain opening
- Auto top-off oil options available or simply refill with the push of a button

### CONTROLLER OPTIONS:

#### Touchscreen Control

- Brightness adjustment
- Product key graphics
- USB port for data transfer
- Language support & recipe storage

#### 12 Button Computer Control - Matchless Ignition

- Greater Temperature Control - plus or minus 1°F reactivity from set temperature
- Better recovery, increased production
- Melt Cycle
- Ease of Use: 12 product buttons
- Programmable temperature, cook, shake, and hold functions; volume levels
- Anti-boil over mode
- Consistent Product - elastic time
- Instant On - Controller calls for heat as soon as a timer is activated instead of waiting for the temperature drop



SELVRF-2/FD shown with filter drawer, casters, and 12 Button Computer

AVAILABLE WITH

# SOS

SmartOIL SENSOR

Know precisely when to re-use oil & when to change it to ensure top quality food & save on oil costs

# REDUCED OIL VOLUME FRYER (ROV)

<b>ROV RACK FRYER - ELECTRIC ⚡</b>						
Model Number	Oil Capacity (Lbs.)	Power (kW)	Frying Area	Cook Depth	Approx Ship Wt. (lbs.)	Approx Cubic Feet
CE SFSELVRF	76	17	14"x 18"	10"	415	56
CE SELVRF-2/FD	76 each	17	14"x 18" each	10"	930	84
<b>ROV RACK FRYER - GAS 🔥</b>						
Model Number	Oil Capacity (Lbs.)	BTUs/Hr	Frying Area	Cook Depth	Approx Ship Wt. (lbs.)	Approx Cubic Feet
CE SFSGLVRF	76	125,000	14"x 18"	10"	415	56
CE SGLVRF-2/FD	76 each	250,000	14"x 18" each	10"	930	12
Additional basket and wire goods available on pages 30-31						
<b>ROV RACK FRYER OPTIONS &amp; ACCESSORIES</b>						
Description						
Bulk Oil Option						
Automatic Basket Lifts						
ROV Rack Fryers come standard with casters						

## Automatic Filtration Cycles

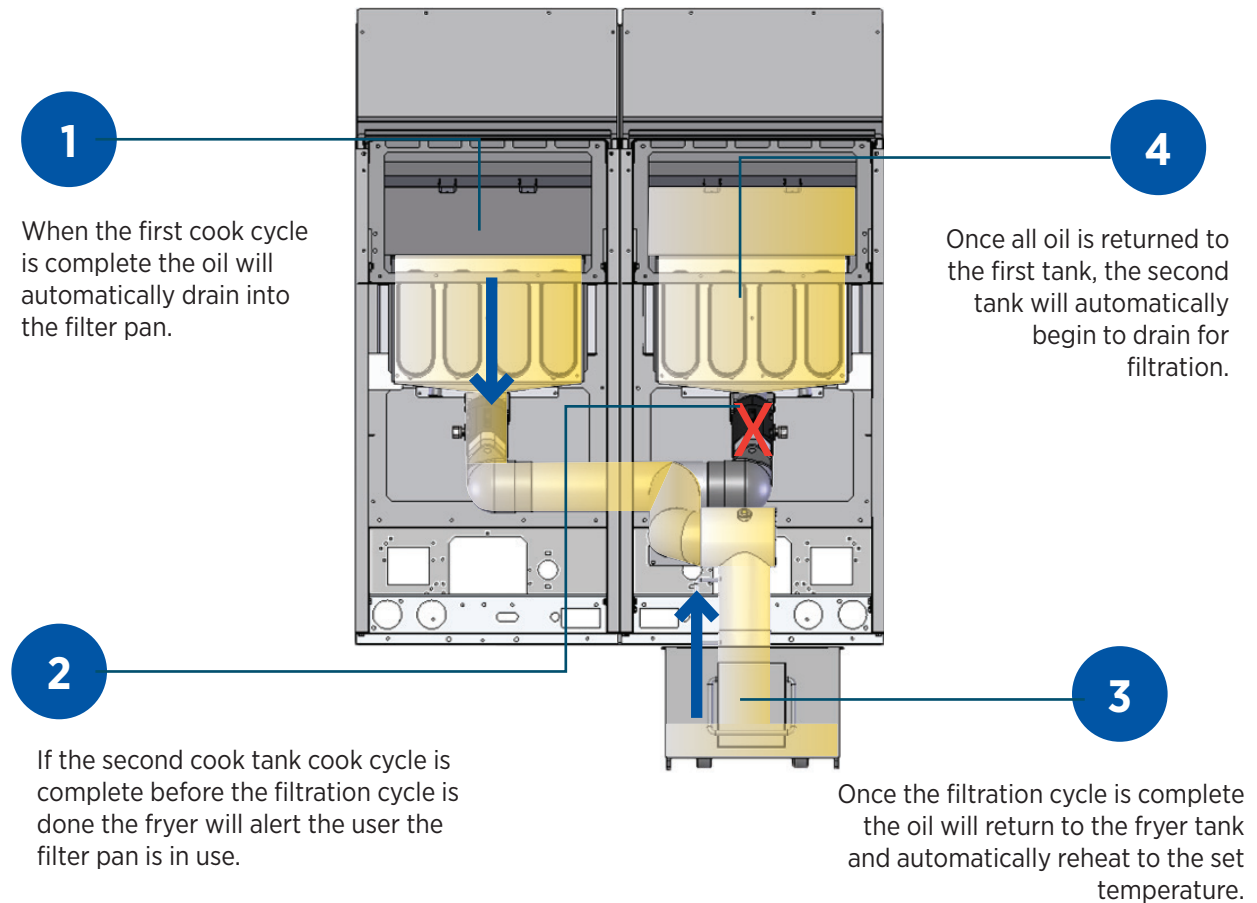

CE CE approvals for individual models may not be available with all options or in all areas. Consult the factory for more information.

# REDUCED OIL VOLUME FRYER (ROV)



## REDUCED OIL VOLUME FRYER GAS & ELECTRIC

### FULLY AUTOMATED FILTRATION SYSTEM AVAILABLE

- Reduce operating costs
- Increase safety for operators who directly handle fresh/waste oil
- Reduces carbon footprint:
  - Less processed oil from first fill
  - ENERGY STAR® Certified
  - Fewer deliveries or waste pickups
  - Better for the workplace
- Maintain high production
- Up To 50% reduction in oil
- Longer oil life
- Filter in as little as 3-4 minutes
- Auto top-off oil options available or simply refill with the push of a button

### CONTROLLER OPTIONS:

#### Touchscreen Control

- Brightness adjustment
- Product key graphics
- USB port for data transfer
- Language support & recipe storage

#### 12 Button Computer Control - Matchless Ignition

- Greater Temperature Control - plus or minus 1°F reactivity from set temperature
- Better recovery, increased production
- Melt Cycle
- Ease of Use: 12 product buttons
- Programmable temperature, cook, shake, and hold functions; volume levels
- Anti-boil over mode
- Consistent Product - elastic time
- Instant On - Controller calls for heat as soon as a timer is activated instead of waiting for the temperature drop



**10  
YEAR  
FRY POT  
WARRANTY**

SSHLV14-2 shown with filter drawer, casters, and touch screen

Available with unique 18" wide tank



\*Some models available with Open Kitchen Technology

AVAILABLE WITH



Know precisely when to re-use oil & when to change it to ensure top quality food & save on oil costs

# REDUCED OIL VOLUME FRYER (ROV)

REDUCED OIL VOLUME FRYERS - STANDARD WITH 12 BUTTON COMPUTER CONTROL - ELECTRIC ⚡			
Model Number	Oil Capacity (Lbs.)	Cook Area (W x D)	KW/Hr
CE SELV14-C/FD	30	13.5" x 14.8"	17
CE SELV184-C/FD	40	17.5" x 14.8"	17
CE SELV14T-C/FD	15ea	6.3" x 14.8"	8.5ea
CE SELV14X-C/FD	30	13.5" x 14.8"	14
CE SELV184X-C/FD	40	17.5" x 14.8"	14
CE SELV14TX-C/FD	15ea	6.3" x 14.8"	7ea
REDUCED OIL VOLUME FRYERS - STANDARD WITH 12 BUTTON COMPUTER CONTROL - GAS 🔥			
ENERGY STAR® Qualified Models are marked with an asterisk (*)			
Model Number	Oil Capacity (Lbs.)	Cook Area (W x D)	BTUs/Hr
CE SSHLV14-C/FD*	32	13" x 13.6"	72,500
CE SSHLV184R-C/FD	42	17" x 13.6"	100,000
CE SSHLV14T-C/FD	17ea	6.9" x 13.6"	37,000ea

OPTIONS & ACCESSORIES	
Description	
Upgrade to OneTouch Control (OT) from Standard 12 Button - full pot	
Upgrade to OneTouch Control (OT) from Standard 12 Button - split pot	
SOS - One Sensor per Battery	
Auto Top-off - add per full pot	
Auto Top-off - add per split pot	
Auto Filtration - per full pot	
Auto Filtration - per split pot	
Stainless Steel Back (SS) Per Unit	
Basket Lifts (Add 100 lbs to fryer weight. Basket lifts add 4-1/2" to overall depth of fryer). *Only one needed for dual tank fryers	
PFW-1 Built-in Foodwarmer, 750watt for BNB Solstice Bread and Batter Dump Station	
SELVBNB14 or SSHLVBNB14	
SSHLVBNB14 BASKET TOWER	
PCFLV14 Crisp-N-Hold	
PCFLV18 Crisp-N-Hold	
Power Cord and Plug - 6 foot, 4 Gauge power cord, with NEMA 15-60P plug Option available for Domestic SELV models, 14KW and 17KW, 3 phase, 208V or 240V fryers only	

CE CE approvals for individual models may not be available with all options or in all areas. Consult the factory for more information.

# REDUCED OIL VOLUME FRYER (ROV)

## REDUCED OIL VOLUME FRYER SYSTEMS - ELECTRIC ⚡

Model Number

- CE SELV14C-2/FD
- CE SELV14TC-2/FD
- CE SELV14C-3/FD
- CE SELV14C-4/FD
- CE SELV14C-2/14T/FD
- CE SELV14C/14T-2/FD
- CE SELV14C-2/14T-2/FD
- CE SELV14C/184/FD

## REDUCED OIL VOLUME FRYER SYSTEMS - GAS 🔥

Model Number

- CE SSHLV14C-2/FD\*
- CE SSHLV14TC-2/FD
- CE SSHLV14C-3/FD\*
- CE SSHLV14C-4/FD\*
- CE SSHLV14C-2/14T/FD
- CE SSHLV14C/14T-2/FD
- CE SSHLV14C-2/14T-2/FD
- CE SSHLV14C/184/FD

## SOLSTICE FILTER DRAWER

See Pages 22 & 23 for Solstice Filter Drawer and Oil Reclamation Options



SF-SELV184

CE CE approvals for individual models may not be available with all options or in all areas. Consult the factory for more information.



## SOLSTICE SUPREME - SSH GAS

### ENERGY SAVING HIGH PRODUCTION FRYING

- Solid state control standard
- Matchless ignition
- Self cleaning burner & down draft protection
- Stainless steel tank, front, door and sides
- Drain valve interlock safety switch
- 9" legs

### OPTIONAL FEATURES

- Solstice Filter Drawer
- Oil filtration in a fryer battery
- Solstice SoloFilter-Oil filtration in a single fryer
- 9" casters optional
- Fry Vat covers, optional
- Stainless Steel Back (SS) Per Unit
- Basket Lifts
- PFW-1 built-in foodwarmer, 750watt for BNB Solstice bread and batter dump station
- Multi-Zone computer control - not available on split tank fryers
- SSTC Back-up controller- can be added to any fryer that uses a digital or computerized control

### SSH CONTROLLER OPTIONS:

All controller options include the patented self cleaning burner and downdraft protection system, matchless ignition and drain valve interlock switch.

#### Touchscreen Control

- On-screen brand logo
- Brightness adjustment
- Product key graphics
- USB port for data transfer
- Language support & recipe storage

**Multi-Zone Computer** - All the features of the Computerized Control plus:

- Perfect for 3 basket configuration
- Simple two step process: Select product, then select zone
- Different color zone for each basket
- Eliminates confusion of which product started cooking first

**12 Button Computerized Control** standard with twelve count down timers with elastic "flex time" for more product consistency. Melt cycle, boil-out capability and drain valve interlock switch.

**Digital Control** standard with two count down timers, melt cycle, boil-out capability and drain valve interlock switch.

**Solid State Thermostat** standard with melt cycle, boil-out capability and drain valve interlock switch.



SSH Mixed Battery with optional 12-Button Computer, Digital and Solid State controls, basket lifts, filter drawer and casters

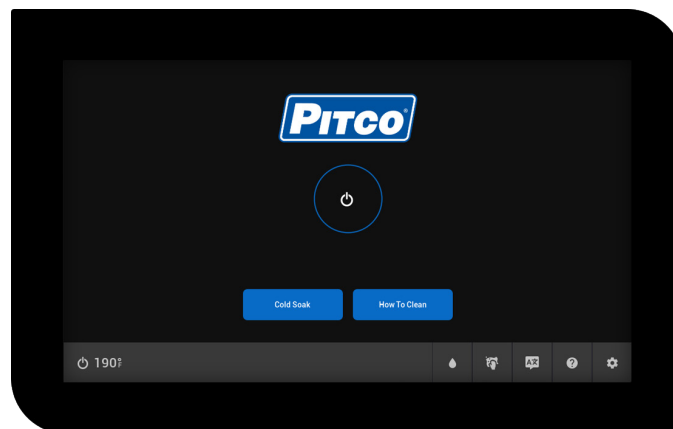

# SOLSTICE SUPREME HIGH EFFICIENCY GAS FRYERS

## SOLSTICE SUPREME HIGH EFFICIENCY, HIGH PRODUCTION FRYERS

All SSH Gas Fryer Systems standard with rear "T" manifold and 9" legs. Casters available below. ENERGY STAR® Qualified Models are marked with an asterisk (\*)

Model Number	Oil Capacity (Lbs.)	Cook Area (W x D)	BTUs	Approx Ship Wt. (lbs.)	Approx Cubic Feet
SSH55*	40-50	14"x14"	80K	230	34.6
SSH55R	40-50	14"x14"	100K	240	34.6
SSH55T	20-25ea	7"x14"ea	40Kea	255	34.6
SSH55TR	20-25ea	7"x14"ea	50Kea	260	34.6
SSH75*	75	18"x18"	105K	275	34.6
SSH75R	75	18"x18"	125K	285	34.6
SSH60*	50-60	14"x18"	80K	230	34.6
SSH60R	50-60	14"x18"	100K	255	34.6
SSH60W*	50-60	18"x14"	100K	275	34.6
SSH60WR	50-60	18"x14"	125K	270	34.6

Note 1: To meet CSA specification, all gas fryers with basket lifts must be ordered with casters and installed with flexible gas connector with restraining device. Basket lifts add 4-1/2" to overall depth of fryer. Add 100 lbs to fryer weight. Not available with SSTC controller

### SOLSTICE FILTER DRAWER

See Pages 22 & 23 for Solstice Filter Drawer, Portable Filter and Oil Reclamation Options

### SOLSTICE BREAD AND BATTER - BNB DUMP STATION

Standard with 4-5/8" recessed pan and screen. Scooped pan liner available at no additional cost in lieu of screen

Model Number	Approx Ship Wt. (lbs.)	Approx Cubic Feet
SSHBNB55	150	17
SSHBNB75	150	23
PCF14 (Crisp'N Hold pg 24)	210	17
PCF18 (Crisp'N Hold pg 24)	217	23
SSH-BNB-55-BT Basket Tower - Baskets sold separately; 10 twin baskets required - see page 30	-	-
SSH-BNB-75-BT Basket Tower - Baskets sold separately; 10 twin baskets required see page 30	-	-

 CE approvals for individual models may not be available with all options or in all areas. Consult the factory for more information.

# SOLSTICE SUPREME HIGH EFFICIENCY GAS FRYERS

## OPTIONS & ACCESSORIES

### Description

Bulk Fresh Oil Piping Connection Kit (per battery)

Stainless Steel Back (SS) Per Unit

Basket Lifts (see note 1 above) \*Only one needed for dual tank fryers

PFW-1 Built-in Foodwarmer, 750watt for BNB Solstice Bread and Batter Dump Station

Multi-Zone Computer control or Profile Computer control not available on split tank fryers

Signal IQ

SSTC Back-up Controller (Full) can be added to any fryer that uses a Digital or 12 Button Control

SSTC Back-up Controller (Split) - can be added to any fryer that uses a Digital or 12 Button Control

Foam Zone Protector

## SMART SOLSTICE OPTIONS

### Description

Autofiltration (AF) - can be added to any fryer that uses 12 Button Control or OneTouch (MUST include Smart Pump & Drain) \$ per pot

Autotop off - can be added to any fryer that uses 12 Button Control or OneTouch. (MUST include AF)

SOS Smart Oil Sensor - can be added to any fryer that uses 12 Button Control or OneTouch

Powered Waste and Fresh Oil Management. (MUST include AF) Price per unit

Smart Pump & Drain (MUST include AF)

Smart Pump & Drain (MUST include AF)



SSH55T with optional digital control and casters

## SOLSTICE FRYERS

### ELECTRIC

**COOK MORE PRODUCT, MORE EFFICIENTLY &  
PROVIDE AN IMPROVED OPERATING ENVIRONMENT**

- Solid state control standard
- Universal control system mix and match controls to fit your needs
- Mix and match cabinets: any Solstice Electric models can be combined to create the perfect combination for your individual needs
- Mercury free relays - reliable and safe for the environment
- Front serviceable - all components are accessible from the front to make service and maintenance faster and easier
- The heating element can be removed without access to the back of the fryer
- 1-1/4" full port drain valve - clog free draining
- Safe fixed element design - designed to eliminate oil migration through pivot components

### CONTROLLER OPTIONS

#### Touchscreen Control

- On-screen brand logo
- Brightness adjustment
- Product key graphics
- USB port for data transfer
- Language support & recipe storage

#### Multi-Zone Computer - All the features of the Computerized Control plus:

- Perfect for 3 basket configuration
- Simple two step process: Select product, then select zone
- Different color zone for each basket
- Eliminates confusion of which product started cooking first

**12 Button Computerized Control** standard with twelve count down timers with elastic "flex time" for more product consistency. Melt cycle, boil-out capability and drain valve interlock switch.

**Digital Control** standard with two count down timers, melt cycle, boil-out capability and drain valve interlock switch.

**Solid State Thermostat** standard with melt cycle, boil-out capability and drain valve interlock switch.



SE14 shown with optional digital control and casters



# SOLSTICE ELECTRIC FRYERS

## SOLSTICE ELECTRIC FRYERS ⚡

For Use In A System Or Stand Alone | ENERGY STAR® Qualified Models are marked with an asterisk (\*)

Model Number	Oil Capacity (Lbs.)	Power kW	Cook Area (W x D)	Approx Ship Wt. (lbs.)	Approx Cubic Feet
SE14X*	40-50	14	14"x14"	200	17.8
SE14**	40-50	17	14"x14"	200	17.8
SE14R*	40-50	22	14"x14"	200	17.8
SE14T	20-25ea	8.5ea	7"x14"ea	230	17.8
SE18* **	70-90	17	18"x18"	226	34.6
SE18R	70-90	22	18"x18"	226	34.6
SE184*	60	17	18"x14"	226	34.6
SE184R	60	22	18"x14"	226	34.6

Note 1: Add 100 lbs to fryer weight. Basket lifts add 4-1/2" to overall depth of fryer. Basket lifts are wired at the factory for fryer voltage on 208v, 240v models. All 440-480v models require an additional 115v supply to power the basket lifts and filter systems

## SOLSTICE FILTER DRAWER

See Pages 22 & 23 for Solstice Filter Drawer, Portable Filter and Oil Reclamation Options

## SOLSTICE BREAD AND BATTER - BNB DUMP STATION

Standard with 4-5/8" recessed pan and screen. Scooped pan liner available at no additional cost in lieu of screen

Model Number	Approx Ship Wt. (lbs.)	Approx Cubic Feet
SEBNB14	145	17
SEBNB18	150	23
PCF14 (Crisp'N Hold pg 24)	155	17
PCF18 (Crisp'N Hold pg 24)	165	23
SEBNB55-BT Basket Tower - Baskets sold separately; 10 twin baskets required - see page 30	160	18

## OPTIONS & ACCESSORIES

### Description

Stainless Steel Back (SS) Per Unit

Basket Lifts \*Only one needed for dual tank fryers

PFW-1 Built-in Foodwarmer, 750watt for BNB Solstice Bread and Batter Dump Station

Multi-Zone Computer control or Profile Computer control not available on split tank fryers

SSTC Back-up Controller- can be added to any fryer that uses a Digital or 12 Button Control

480VAC

Power Cord and Plug - 6 foot, 4 Gauge power cord, with NEMA 15-60P plug. Option available for Domestic SE models, 14KW and 17KW, 3 phase, 208V or 240V fryers only

Foam Zone Protector

## SMART SOLSTICE OPTIONS

### Description

Autofiltration (AF) - can be added to any fryer that uses 12 Button Control or OneTouch (MUST include Smart Pump & Drain) \$ per pot

Autotop off - can be added to any fryer that uses 12 Button Control or OneTouch (MUST include AF)

SOS Smart Oil Sensor - can be added to any fryer that uses 12 Button Control or OneTouch

Powered Waste and Fresh Oil Management. (MUST include AF) Price per unit

Smart Pump & Drain (MUST include AF)

See Prepackaged Electric Fryer Systems on Page 16

CE CE approvals for individual models may not be available with all options or in all areas. Consult the factory for more information.



\*\* Model available with Open Kitchen Technology

[P] +1 603.225.6684 | [www.pitco.com](http://www.pitco.com)



## FILTER-READY SOLSTICE GAS FRYERS

### GAS

#### HIGH PRODUCTION, 57% THERMAL EFFICIENT

##### **Automatic Self Cleaning Burners Standard (Patented)**

With the push of a button, our matchless ignition system ignites the pilot. This begins a 30 second automatic self cleaning burner procedure, which ensures optimal burner efficiency. This procedure ensures that the burners stay clean and efficient all day, every day... PERIOD!

(not available with millivolt control)

**Matchless Ignition\*** Ignites the pilot once a each day when the power is turned on.

**Universal Control System\*** Mix and match controls to fit your needs. 12 Button Computer Control, Digital Control, Solid State, or use the Solid State control as a back-up to the Computer or Digital.

**Front Serviceable -** All components are accessible from the front to make service and maintenance faster and easier.

\*Only available with upgraded controls.

Millivolt thermostat standard on Solstice Gas Fryers

#### CONTROLLER OPTIONS

**12 Button Computerized Control** standard with twelve count down timers with elastic "flex time" for more product consistency. Melt cycle, boil-out capability and drain valve interlock switch.

**Digital Control** standard with two count down timers, melt cycle, and drain valve interlock switch.

**Solid State Thermostat** standard with melt cycle, boil-out capability and drain valve interlock switch.

**Millivolt Thermostat** standing pilot control with mechanical thermostat. Standard on all Solstice gas fryers.



SG14R-2FD shown with optional filter drawer & casters



### SOLSTICE BURNER DESIGN

The solstice burner draws more primary air for improved air gas mixture. The baffle design causes a scrubbing action of the flame, squeezing more heat out. This design causes the baffle to get into radiant mode quicker for improved temperature recovery and faster cooking.

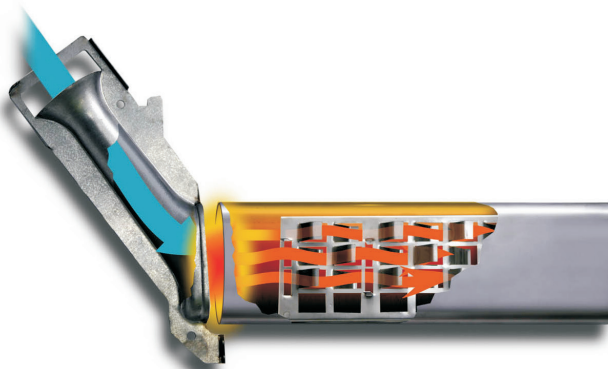

# SOLSTICE GAS FRYERS

## SOLSTICE GAS FRYERS

Built in filter drawer filtration for use in multi-fryer systems or a standalone fryer | All Solstice Gas Systems standard with rear "T" gas manifold and 9" legs | For prepackaged systems see page 16

Model Number	Oil Capacity (Lbs.)	BTUs	Cook Area (W x D)	Approx Ship Wt. (lbs.)	Approx Cubic Feet
SG14RS	40-50	122K	14"x14"	208	17

Note 1: Basket Lifts not available with Millivolt or SSTC controller. To meet CSA requirements, all fryers with basket lifts must be ordered with casters and installed with a FLEXIBLE GAS CONNECTOR with restraining device. Add 100 lbs to fryer weight. Basket lifts add 4-1/2" to overall depth of fryer

## SOLSTICE FILTER DRAWER

See Pages 22 & 23 for Solstice Filter Drawer, Portable Filter and Oil Reclamation Options

## SOLSTICE BREAD AND BATTER - BNB DUMP STATION

Standard with 4-5/8" recessed pan and screen. Scooped pan liner available at no additional cost in lieu of screen

Model Number	Approx Ship Wt. (lbs.)	Approx Cubic Feet
SGBNB14	145	17
SGBNB18	150	23
PCF14 (Crisp'N Hold pg 24)	155	17
PCF18 (Crisp'N Hold pg 24)	165	23

## OPTIONS & ACCESSORIES

### Description

Bulk Fresh Oil Piping Connection Kit (per battery)

Stainless Steel Back (SS) Per Unit

PFW-1 Built-in Foodwarmer, 750watt for BNB Solstice Bread and Batter Dump Station

Multi-Zone Computer control or Profile Computer control

Backup T-Stat-Full Tank

See Prepackaged Gas Fryer Systems on Page 16



\* Some models available with Open Kitchen Technology

**CE** CE approvals for individual models may not be available with all options or in all areas. Consult the factory for more information.

# SOLSTICE SUPREME - PACKAGED SYSTEMS

<b>SSH FRYING SYSTEMS WITH FILTER - Select From These Fryer Systems Or Build Your Own On Page 9</b>							
Model SSH55*	Model SSH55R	Model SSH60*	Model SSH60W	Model SSH75*	Suffix SS Stainless Back	Back-up T-stat	Basket Lifts (See Note 1)
Solid State Thermostat - standard with melt cycle, boil-out capability, and drain valve interlock switch							
Digital Control - standard with two count down timers, melt cycle, boil-out capability, and drain valve interlock switch							
12 Button Computerized Control - standard with twelve count down timers with elastic "flex time" for more product consistency. Melt cycle, boil-out capability, and drain valve interlock switch							
OneTouch Control - 10.1" display							
Note 1: To meet AGA/CGA/CSA specification, all gas fryers with basket lifts must be ordered with casters and installed with flexible gas connector with restraining device. Basket lifts add 4-1/2" to overall depth of fryer. Add 100 lbs to fryer weight. Not available with SSTC controller							
<b>SOLSTICE BREAD &amp; BATTER - BNB DUMP STATION</b>							
Standard with 4-5/8" recessed pan and screen. Scooped pan liner available at no additional cost in lieu of screen. Additional BNB accessories on page 29							
				Approx Ship Wt. (lbs.)		Approx Cubic Feet	
BNB-SSH55				150		17	
BNB-SSH75				150		23	
PCF14 (Crisp'N Hold pg 24)				210		17	
PCF18 (Crisp'N Hold pg 24)				217		23	
If BNB or PCF is added between two fryers, an additional piping charge will apply							
Flush Hose - to assist in rinsing the tank during oil filtration							
Filter Heater - for use with solid shortening							
Filter Heater - for use with liquid shortening (one-time charge)							
PFW-1 Built-in Foodwarmer, 750watt							
Paperless Filter Option							
<b>OPTIONS &amp; ACCESSORIES</b>							
Autofiltration (AF) - can be added to any fryer that uses 12 Button Control or OneTouch (MUST include Smart Pump & Drain) \$ per pot							
SOS Smart Oil Sensor - can be added to any fryer that uses 12 Button Control or OneTouch							
Basket Lifts *Only one needed for dual tank fryers							
<b>Oil Handling</b> - Waste oil piping option (for liquid shortening)							
<b>Oil Handling</b> - Solid shortening upgrade (for solid shortening)							
Fresh Bulk Oil Connection							
<b>APPROXIMATE SHIPPING WEIGHT CHART (LBS)(With Filter)</b>							
Fryers	1	2	3	4	5	6	
SSH55/55R	350	550	785	980	1195	1410	
SSH60/60W/75	380	602	843	1084	1325	1566	

\*For BNB dump station, add 150 lbs to above weight  
 \*For basket lifts, add 100 lbs per fryer to above weight

# SOLSTICE ELECTRIC - PACKAGED SYSTEMS

## SOLSTICE ELECTRIC FRYER SYSTEMS WITH FILTER - ELECTRIC ⚡

Select From These Fryer Systems Or Build Your Own On Page 12. All Solstice Electric Fryer Systems standard with 9" legs. Casters available below

Model SE14X* (14kW)	Model SE14S (17kW)	Model SE14RS* (22kW)	Model SE18S (17kW)	Model SE18RS (22kW)	Suffix SS Stainless Back	Back-up T-stat	Basket Lifts (See Note 1)
Solid State Thermostat - standard with melt cycle, boil-out capability, and drain valve interlock switch							
Digital Control - standard with two count down timers, melt cycle, boil-out capability, and drain valve interlock switch							
12 Button Computerized Control - standard with twelve count down timers with elastic "flex time" for more product consistency. Melt cycle, boil-out capability, and drain valve interlock switch							
OneTouch Control - 10.1" display							
Note 1: Basket Lifts not available with SSTC controller. Add 100 lbs to fryer weight. Basket lifts add 4-1/2" to overall depth of fryer. Basket lifts are wired at the factory for fryer voltage on 208v, 240v models. All 440-480v models require an additional 115v supply to power the basket lifts							

## SOLSTICE BREAD & BATTER - BNB DUMP STATION

Standard with 4-5/8" recessed pan and screen. Scooped pan liner available at no additional cost in lieu of screen. Additional BNB accessories on page 29

	Approx Ship Wt. (lbs.)	Approx Cubic Feet
BNB-SE14	150	17
BNB-SE18	150	23
PCF-14 (Crisp'N Hold pg 24)	210	17
PCF-18 (Crisp'N Hold pg 24)	217	23
If BNB or PCF is added between two fryers, an additional piping charge will apply		
Flush Hose - to assist in rinsing the tank during oil filtration		
Filter Heater - for use with solid shortening		
PFW-1 Built-in Foodwarmer, 750watt		
Paperless Filter Option		
480 VAC		
Power Cord and Plug-6 foot, 4 gauge power cord with NEMA 15-60P Plug, Option available for Domestic SE models, 14KW and 17KW 3 phase, 208V or 240V fryers only		
<b>Oil Handling</b> - Waste oil piping option (for liquid shortening)		
<b>Oil Handling</b> - Solid shortening upgrade (for solid shortening)		
Fresh Bulk Oil Connection		

## APPROXIMATE SHIPPING WEIGHT CHART (LBS) (With Filter)

Fryers	1	2	3	4	5	6
SE14X/SE14/SE14R	350	550	785	980	1195	1410
SE18S/SE18R	380	602	843	1084	1325	1566

\*For BNB dump station, add 150 lbs to above weight

\*For basket lifts, add 100 lbs per fryer to above weight. For systems with SE14TS, SE14TRS Twin Tank fryers or mix and match configurations, please contact your Pitco representative or call the factory for pricing assistance

# SOLSTICE GAS - PACKAGED SYSTEMS

## SOLSTICE GAS SYSTEMS WITH FILTER - GAS

Select From These Systems Or Build Your Own On Page 14

All Solstice Gas Fryer Systems standard with rear "T" manifold and 9" legs. Casters available below

Model SG14RS	Suffix SS Stainless Back	Back-up T-stat	Basket Lifts (See Note 1)
Millivolt Thermostat			
Solid State Thermostat - standard with melt cycle, boil-out capability, matchless ignition and drain valve interlock switch			
Digital Control - standard with two count down timers, melt cycle, boil-out capability, matchless ignition and drain valve interlock switch			
12 Button Computerized Control - standard with twelve count down timers with elastic "flex time" for more product consistency. Melt cycle, boil-out capability, and drain valve interlock switch			

Note 1: To meet CSA specification, all gas fryers with basket lifts must be ordered with casters and installed with flexible gas connector with restraining device. Basket lifts add 3-7/8" to overall depth of fryer. Not available with Millivolt or Solid State

## SOLSTICE BREAD & BATTER - BNB DUMP STATION

Standard with 4-5/8" recessed pan and screen. Scooped pan liner available at no additional cost in lieu of screen. Additional BNB accessories on page 29

	Approx Ship Wt. (lbs.)	Approx Cubic Feet
SGBNB14	150	17
SGBNB18	150	23
PCF14 (Crisp'N Hold pg 24)	210	17
PCF18 (Crisp'N Hold pg 24)	217	23

If BNB or PCF is added between two fryers, an additional piping charge will apply.

Flush Hose - to assist in rinsing the tank during oil filtration

Filter Heater - solid shortening

Filter Heater - for use with liquid shortening

PFW-1 Built-in Foodwarmer, 750watt

Paperless Filter Option

## APPROXIMATE SHIPPING WEIGHT CHART (LBS)

Fryers	1	2	3	4	5	6
SG14	350	550	785	980	1195	1410

\*For BNB dump station, add 150 lbs to above weight | \*For basket lifts, add 100 lbs per fryer to above weight

### Bulk Waste Oil Handling Options

Waste oil piping option (for liquid shortening)

Solid shortening upgrade (for solid shortening)



SG14R-2 shown with optional filter drawer & casters



**DON'T FORGET  
ACCESSORIES**  
See pages 28-31 for all  
available accessories

# Baskets

Twin,  
Triple, or Full  
Options Available

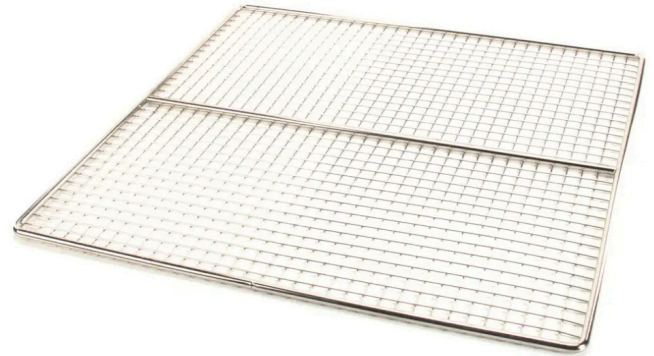

# Tank Screen



Tank Cover



Splash Guard

# Covers & Guards

**Racks and Mesh  
Screens For Gas  
and Electric Fryers**

Check out some other  
product specific accessories  
on the designated  
product pages

For Fryers and  
Pasta Cookers



## STANDARD FRYERS GAS AND ELECTRIC

### Model E35 - Electric Floor Fryer

- Stainless steel tank, front, door and sides
- Sealed construction heating elements with high temperature alloy stainless steel sheath





### ENERGY STAR® QUALIFIED MODELS

#### Model VF65

- 40% less gas with same production rate as a 65C+S
- 65lb Oil Capacity
- 95,000 BTU

#### Model VF35-ES

- 35lb Oil Capacity
- 70,000 BTU

ECONOMY - GAS 						
(Standalone fryers not available with filtration) See page 22 for portable filtration systems						
Model Number	Oil Capacity (Lbs.)	BTUS	Cook Area W x D	Approx Ship Wt. (lbs.)	Approx Cubic Feet	
CE 35C+	35-40	90,000	14" x 14"	161	17	
40D	40-45	107,000	14" x 14"	181	17	
45C+	42-50	122,000	14" x 14"	181	17	
CE 65C+	65-80	150,000	18" x 18"	226	23	
STANDARD SOLSTICE - GAS 						
Stand alone only. Millivolt control only. Not available with Filter Drawer filtration system or in a battery						
Model Number	Oil Capacity (Lbs.)	BTUS	Cook Area W x D	Approx Ship Wt. (lbs.)	Approx Cubic Feet	
CE SG14	40-50	110,000	14"x 14"	200	17	
CE SG14R	40-50	122,000	14"x 14"	208	17	
CE SG14T	20-25 each	50000 each	14"x 14"	230	17	
CE SG18	70-90	140,000	18" x 18"	226	23	
Casters, covers and other accessories available on page 30						
ENERGY STAR FRYER - GAS 						
Free Standing, stand alone fryer   Millivolt control only   Energy Star Qualified Models are marked with Asterisk*						
Model Number	Oil Capacity (Lbs.)	BTUS	Cook Area W x D	Approx Ship Wt. (lbs.)	Approx Cubic Feet	
CE *VF35-ES	35	70,000	14"x 13-5/8"	161	17	
CE VF65	65	95,000	18"x17 11/32"	180	23	
COUNTERTOP FRYER - GAS 						
Models not available with Filter Drawer filtration   See page 22 for portable filter systems   Energy Star Qualified Models are marked with Asterisk*						
Model Number	Oil Capacity (Lbs.)	BTUs	Cook Area W x D	Approx Ship Wt. (lbs.)	Approx Cubic Feet	
CE SGC	35	70,000	14"x 13-5/8"	150	17	
A 70,000 BTU counter top version of our popular Solstice fryer. With a 13" wide cook surface, this fryer uses standard fry baskets. The unit can be flush mounted, or on 4" flange legs that are included						
ENERGY STAR FRYER - ELECTRIC 						
Model Number	Oil Capacity (Lbs.)	Power (kW)	Cook Area W x D	Approx Ship Wt. (lbs.)	Approx Cubic Feet	Cutout Dimensions
*E35	35	15	14"x 14"	200	17	15"x 32-1/8"

CE CE approvals for individual models may not be available with all options or in all areas. Consult the factory for more information.

\*Energy Star Model

## MEGAFRY FRYERS

GAS

HIGH EFFICIENCY & HIGH PRODUCTION

### FEATURES

- High Efficiency & High Production
- Upgrade controls available
- Optional filtration system
- Standard with stainless steel tank, front, sides and splashback
- Standard with solid state control
- Upgrade controls available
- Standard with Large Baskets (A4514702)

**145.6  
lbs/hour**  
36% more than  
SSH75R!

SGM24 with 12 Button  
Computer & optional casters  
and 1 large/2 small  
basket configuration



Submerger Option

### Basket Options

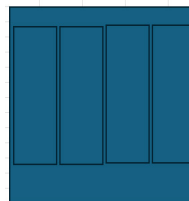

Option 1  
4 "small" A4514701  
baskets

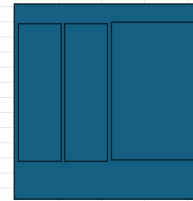

Option 2  
2 "small" A4514701  
baskets, 1 "large"  
A4514702 basket

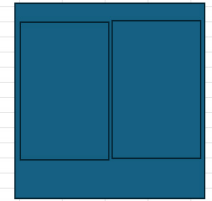

Option 3  
2 "large" A4514702  
baskets

MEGAFRY - GAS					
Model Number	Oil Capacity (Lbs.)	BTUs	Cook Area W x D	Approx Ship Wt. (lbs.)	Approx Cubic Feet
CE SGM24	140-150	165,000	24"x24"	375	56
MEGAFRY-BASKET OPTIONS - QUANTITY REQUIRED					
	SGM24				
Small A4514701		4		2	-
Large A4514702		-		1	2
OPTIONS & ACCESSORIES					
Description					
Submerger Option					

CE CE approvals for individual models may not be available with all options or in all areas. Consult the factory for more information.

# FLAT BOTTOM FRYER

## FLAT BOTTOM FRYER

### GAS

- Perfect for free float frying, no tubes
- 24" x 24" and 18" x 24" sizes
- Standard mild steel tank
- Matchless Ignition
- Standard stainless steel front, sides and splashback
- No combustion blower
- Optional filter system

FLAT BOTTOM FRYER - GAS 🔥					
Model Number	Oil Capacity (Lbs.)	BTUs	Cook Area W x D	Approx Ship Wt. (lbs.)	Approx Cubic Feet
FBG18	42-65	100,000	18" x 24"	355	39
FBG24	57-87	120,000	24" x 24"	423	47

### OPTIONS & ACCESSORIES

Description
Tank Divider FBG
Crumb Tray FBG



FBG24X24, FB24X24,  
FD-FLAT BOTTOM WITH OPTIONAL CASTERS

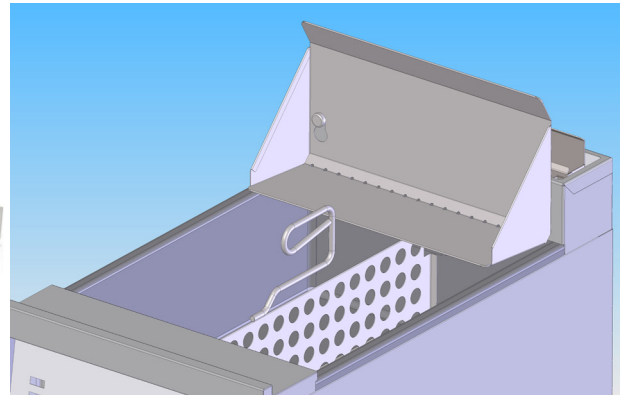

TANK DIVIDER OPTION AND  
CRUMB TRAY ACCESSORY

## OIL HANDLING

### OIL FILTRATION AND RECLAMATION SYSTEMS



P14



FAT VAT

FAT VAT		
Description		
Convenient, safe oil transport system holds 40 pounds (5.3 gallons)		
PORTABLE FILTRATION		
Filter requires separate power connection. For use with gas or electric fryers		
Filter Model Number	Oil Capacity (Lbs.)	Filter mounted on 2" casters For use with:
CE P14	55	All 14 size fryers
CE P18	75	All 18 size fryers
CE RP14	55	All 14 size fryers (Reversible Pump)
CE RP18	75	All 18 size fryers (Reversible Pump)

## OIL RECLAMATION



**With Pitco's internal oil reclamation system,** a third party oil company can install their holding system and connect it directly to a Pitco fryer system. This means an operator has no spilling and no burning hazards when it comes to the disposal of used oil. Pitco's filter pump will deliver used oil to a third party holding tank. Just another way Pitco is saving its customers money. Tie into a third party remote oil system with waste oil piping option, for use with Solstice Filter.

Add-On Options
Waste oil piping option (for liquid shortening)
Solid shortening upgrade (for solid shortening)
Fresh Bulk Oil Connection

## SOLSTICE FILTER DRAWER

SMART, SIMPLE AND EASY TO USE

With a 3" drain line, 8 gallon per minute oil pump, & simple two step filter process, what could be easier?

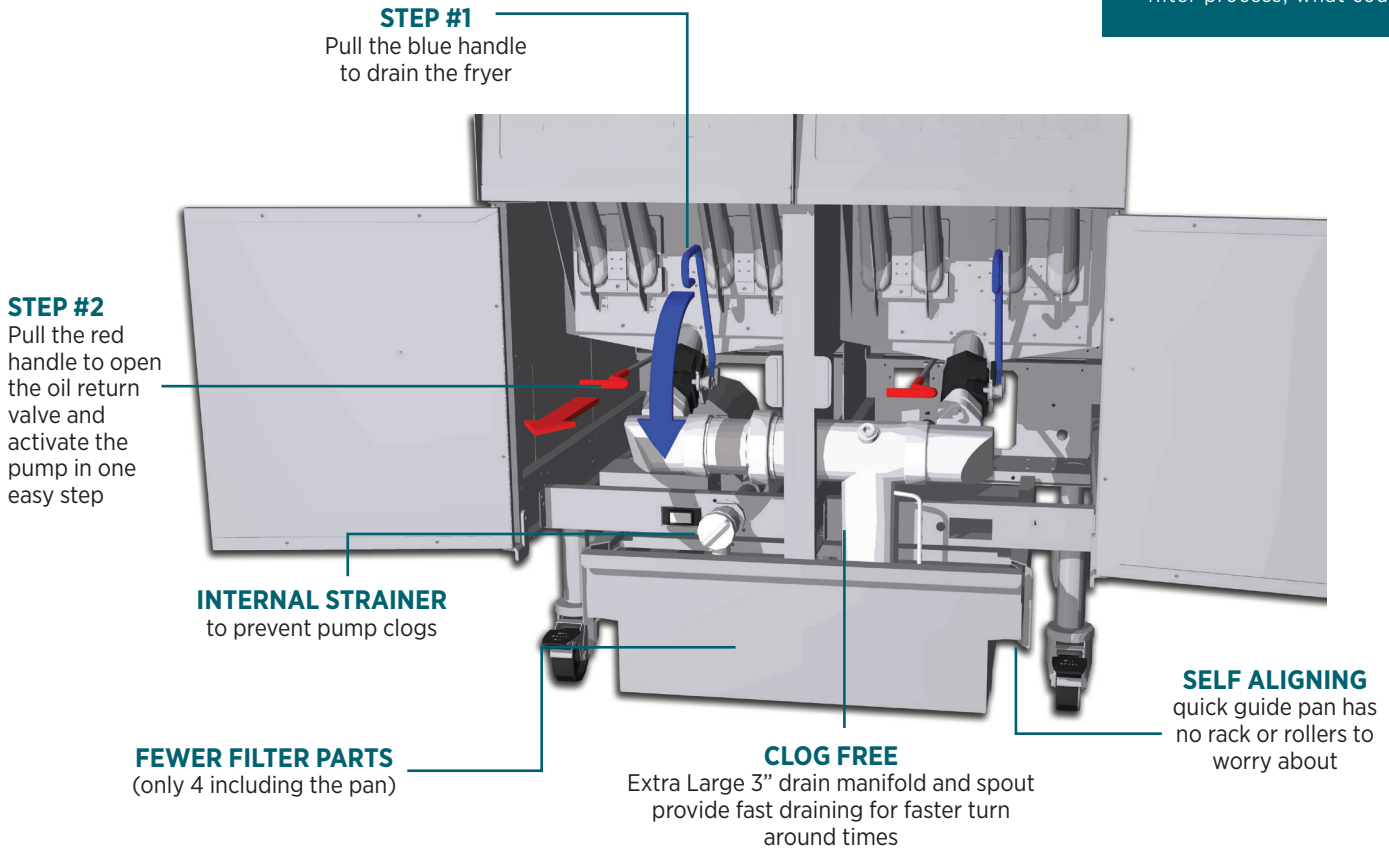

The Solstice Filter System is available on two or more fryers, or the Solstice SoloFilter can be paired with a single gas or electric fryer.

<b>SOLSTICE FILTER DRAWER OIL FILTRATION SYSTEM</b>	
Number of Full and/or Twin Tanks in System - Note: Twin Tank = 2 Tanks Solstice filter requires separate power connection on all gas fryers and electric fryers of 400 or 440 volt	
FD-Solstice	Approx Ship Wt. (lbs.) 150
<b>Filter Drawer Guidelines:</b> 1. All filters for gas fryers are available in 115vac -60hz. All single phase. For other voltages, please contact factory 2. All filters for electric fryers are wired at the factory for the fryer voltage on models from 208-240v. All 440-480v units require an additional 115v supply to power the filter system 3. Tie into a remote oil system with waste oil piping option, for use with Solstice Filter Drawer in a battery of two or more fryers see above for more details	
<b>OPTIONS &amp; ACCESSORIES</b>	
Description	
Flush Hose - to assist in rinsing the tank during oil filtration	
Filter Heater - for use with solid shortening	
Special Piping Charges For All Filter Systems - Piping charge for fryer to add to existing Solstice Battery Filter Drawer or SoloFilter, and piping through a BNB Dump Station	
Paperless Filter Option	

## HOLDING & MERCHANDISING

### ELECTRIC

#### DON'T HOLD YOUR FOOD, CRISP IT!

- Gentle hot air circulation draws air across and through food product for optimal temperature and texture to maintain warmth and crispness
- Heating elements and components located away from oils and vapors
- Large landing zone and adjustable and removable dividers for flexible product holding and easy cleaning
- All stainless steel construction with removable product tray and grease filters for easy cleaning
- Floor models can be used in a Solstice Fryer battery to keep food products crispy, hot, and ready to serve
- Large product landing zone

#### PCC/PCF PERFORMANCE

Food comes out of the fryer at 200° to 210°F. Active air circulation through the food, cools product to holding temperature quickly to reduce moisture loss and stop the cooking process. Excess moisture and oils are wicked away from the product and it remains crispy for an extended time.

#### HEAT LAMP PERFORMANCE

Food comes out of the fryer at 200° to 210°F. Under the heat lamp, heat is released slowly from the product as it continues to cook for as long as 45 minutes. Moisture and oil seep out and collect on the food. The result is overcooked and mushy product after 10-15 minutes.



PCC14



PCF18

#### CRISP N'HOLD CRISPY FOOD STATION - ELECTRIC ⚡

Model Number	Sections	Capacity (Volume) cubic Inches	Approx Ship Wt.(lbs.)
<b>COUNTER MODELS</b>			
CE PCC14	2	837	60
CE PCC18	3	1050	70
CE PCC28	4	1780	98
<b>FLOOR MODELS</b>			
CE PCF14/PCFLV14	2	837/625	155
CE PCF18/PCFLV18	3	1050/821	165

\* Countertop models (PCC) can not be used on existing BNB units

#### SOLSTICE BREAD AND BATTER - BNB DUMP STATION

Model Number	List Price	Approx Ship Wt. (lbs.)	Approx Cubic Feet
BNB (SSH55, SE14, SG14) SELV14, SSHLV14	\$2,977	150	17
BNB (SSH75, SE18, SG18)	\$3,031	150	23

#### OPTIONS & ACCESSORIES

Description
Stainless Steel Back (SS) Per Unit
PFW-1 Built in Foodwarmer, 750watt for BNB Bread and Batter Dump Station
Basket Tower (SELV14, SSHLV14, SSH55, SE14, SG14R)
Basket Tower (SELV184, SSHLV184, SSH75, SE18)



# DISCOVER HOW A RETHERMALIZER ADDS VERSATILITY & MORE



**BLOG**

Check out our blog for more details on how a rethermalizer can change both your menu and your kitchen operations at [www.pitco.com/blog](http://www.pitco.com/blog)

## SOLSTICE BURNER DESIGN

The solstice burner draws more primary air for improved air gas mixture. The baffle design causes a scrubbing action of the flame, squeezing more heat out. This design causes the baffle to get into radiant mode quicker for improved temperature recovery and faster cooking.

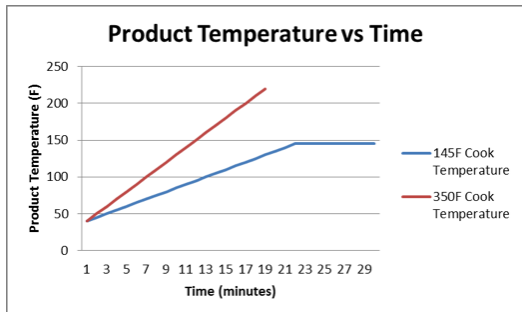
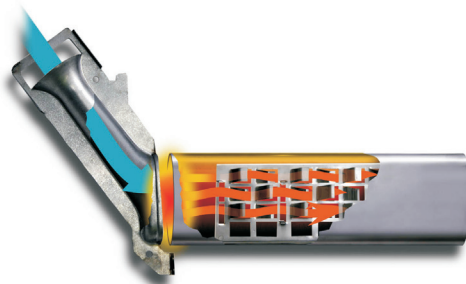

## Add Menu Versatility

Experience the benefits of re-heating high quality food products previously prepared and frozen in bulk. Reduce kitchen labor and training as well as store-site equipment requirements. Pitco Solstice Rethermalizers with marine grade stainless steel hold foods at a precise set temperature.

### Basket Options

Rethermalizers have many options including racks, suitcases and baskets. Racks and suitcases come in 8 or 12 product capacities.

Sous Vide = cooking under vacuum  
Water Retherm = reheating under vacuum

MORE  
**BENEFITS**  
OF RETHERM

REDUCES FOOD WASTE & INCREASES FOOD SAFETY

FOOD REMAINS AT SAFE SERVING TEMPS ALL DAY

HOLDS FOOD AT EXACT SERVING TEMPERATURE

MINIMIZED  
KITCHEN  
LABOR AND  
TRAINING

## SOLSTICE RETHERMALIZER

### GAS & ELECTRIC

- Solstice combustion system for **improved gas efficiency**
- Reduces kitchen labor and training
- Improves kitchen safety
- Gas Self Cleaning Burner system and down draft protection (patented)
- Convenience over range top application
- Exceptional product quality
- Reduces energy usage



CRTE Counter Top Electric Rethermalizer

### WATER RETHERMALIZER - GAS

Model Number	BTUs	Water Capacity (Gallons)	Approx Ship Wt. (lbs.)
SRTG-X (Single)	55,000	17.5	220 lbs.
SRTG-X2 (Dual)	110,000	17.5 ea	477 lbs.

Standard with Digital Thermostat, matchless ignition, automatic water fill, auxiliary manual fill, common drain/ overflow, stainless steel hinged tank cover(s), tube rack, 6" legs. Supplied with cord and plug

### SOLSTICE RETHERMALIZER - ELECTRIC

Model Number	kW	Water Capacity (Gallons)	Approx Ship Wt. (lbs.)
SRTE14-GM (Single)	10.5 kW *	16.5	220 lbs.
SRTE14-2-GM (Dual)	10.5 kW ea*	16.5 ea	477 lbs.

Standard with Digital Thermostat, automatic water fill, auxiliary water fill, common drain/over flow, stainless steel hinged tank cover(s), element rack, 6" legs. No power cord supplied for single phase models, available at additional charge 3 phase. Electric service must be hard wired by a licensed electrician  
\*Power Rating is 8kW at 208V and 10.5kW at 240V

Power Cord and Plug - 6 foot, 4 Gauge power cord, with NEMA 15-60P plug. Option available for SRTE models 3 phase, 208V or 240V appliances only

### COUNTER TOP RETHERMALIZER - ELECTRIC

Model Number	KW	Water Capacity (Gallons)	Approx Ship Wt. (lbs.)
CRTE	6 kW	6	60

### FLOOR MODELS OPTIONS & ACCESSORIES

Description	
Casters - 1/2 Set per tank, minimum 1 set	
Water Quick Disconnect- Self closing single hand operation water supply hose	
1/3 Pan Rails -Holds various sizes of hotel pans to keep foods warm.	Set of 2 for single tank Set of 3 for dual tank

### RACKS

Description	Part Number
8 product/Tall Vertical Food Rack	B4511001
8 product/Vertical Food Rack	B4509402
12 Product Horizontal Food Rack	B4513001

### SUITCASES

Description	Part Number
Food Product Suitcase/Narrow	B4511101
Food Product Suitcase/Wide	B4511102
Food Product Suitcase/Tall Narrow	B4513302
Food Product Suitcase/Tall Wide	B4513301
Suitcase, 2.50" Wide	B4516101

### BASKETS

B4511601
B4511501

## SOLSTICE SUPREME PASTA COOKER

### GAS & ELECTRIC

- Gas Solstice Burner Technology, No Blower or Ceramics
- Gas Self Cleaning Burner System & Down Draft Protection (patented)
- High Efficiency Design
- Standard with 4 Button Digital Controller
- Rinse Faucet Standard on Rinse Station
- Now Includes Standard Water Fill
- Drain "T" Manifold Standard on Pasta Cookers Combined with Rinse Station



SSPE14/ SSRE14

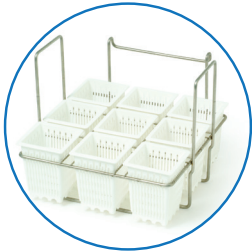

Individual Portion Cups and Rack - (9) 4"x4" cups for use in gas or electric. For cooking or reconstituting of single portions.

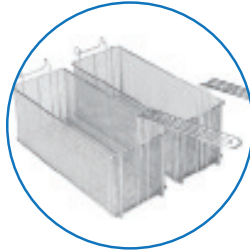

Oblong Baskets - 15-3/4" x 6" x 7" for use with any pasta cooker. Can also be used with dual basket lift. For cooking of smaller portions. Can be used as holding rack for small round baskets, 2 ea.



**Bulk Baskets**  
Small 13-1/4" x 13-1/4" x 9" for use with gas or electric. Small bulk loads up to 5 lbs of dry pasta. Can also be used with single basket lift.



Round Baskets - 4-5/8" or 6-1/4" for use with gas or electric. Standard or fine mesh available. For cooking of various types of pasta or reconstituting of small portions.

<b>SOLSTICE SUPREME PASTA COOKER - GAS</b> 🔥				
Model Number	BTUs	Water Capacity (Gallons)	Approx Ship Wt. (lbs.)	Approx Cubic Feet
SSPG14	60K	12	250	55
SSRS14 Rinse Station	n/a	10	136	17
<b>SOLSTICE SUPREME PASTA COOKER - ELECTRIC</b> ⚡				
Model Number	BTUs	Water Capacity (Gallons)	Approx Ship Wt. (lbs.)	Approx Cubic Feet
SSPE14	12.5	12	177	17
SSRE14 Rinse Station	n/a	10	136	17
<b>SOLSTICE SUPREME PASTA COOKER OPTIONS &amp; ACCESSORIES</b>				
Description				
Quick Set Timer (can not be used with basket lifts)				
Single Basket Lift* (adds 4-1/2" to overall depth)				
Dual Basket Lift* (adds 4-1/2" to overall depth)				
Rinse Tank Insulation				
Drain "T" Manifold (specify when ordering)				
Water Quick Disconnect				
Casters				
Water Saving Flow Regulated Mixing Valve (In addition to standard manual fill) - Available on Gas Units Only				
*Gas units with basket lifts must include casters				

# OPTIONS & ACCESSORIES

<b>FLEXIBLE CONNECTORS (GAS QUICK DISCONNECT)</b> Gas quick disconnect couplings with flexible hose, restraining device and thermal shut-off			
Gas Connector Size	Disconnect BTU Capacity		Part Number
	Single Units	Multiple Units	
3/4" x 36"	240,000	---	B8003102
3/4" x 48"	240,000	---	B8003103
1" x 36"	---	390,000	B8003105
1" x 48"	---	390,000	B8003106
1-1/4" x 36"	---	575,000	B8003108
1-1/4" x 48"	---	575,000	B8003109

<b>FRYERS CLEANING ACCESSORIES</b>		
Description	Use	Part Number
Clean Out Rod	Used to clean fryer drain line	STD-A3301001, SELVA3881001 SSHLV-A3381003, SELV-A3381003
Cleaner - 25 Lbs.	Extends the life of the fryer and shortening	P6071397
Cleaning Brush	High temperature, Teflon cleaning brush	PP10056
Crumb Scoop	Designed to fit between tubes and elements for removal of heavy sediment	Std-B7490701 Twin, SE-B5008101, SSHLV-B500812
Fat Vat	Convenient, safe oil transport system holds 40 pounds (5.3 gallons)	D9109105
Skimmer	Used for removing food particles from the oil surface	PP10725

<b>FILTER ACCESSORIES</b>		
Description	Use	Part Number
Filter Shovel Scoop	Used to remove debris from filter pan	B6681201
Powder	Filter powder - 120, 8 oz. packets	PP10733
Paperless Filter Assembly	(Priced as substitute for standard assembly in new filter system)	

<b>FILTER PAPER</b>					
Part Number	Model Number	Type	Paper Quantity	Gauge	Size
PP10613	Solstice Filter Drawer	Envelope	100	Heavy Duty	18-1/2" x 20-1/2"
A6667104	SFSSH55/T/R, SFSG14R, SFSE14/T/R/TR, ROV Solo & Dual	Envelope	100	Heavy Duty	10" x 20-1/2"
A6667105	ROV Triple and up	Envelope	100	Heavy Duty	14" x 22"
P6071371	P14	Flat	100	Standard	13-1/2" x 24"
PP10612	P14	Flat	100	Heavy Duty	13-1/2" x 24"
P6071373	P18	Flat	100	Standard	17-1/2" x 28"
PP10606	P18	Flat	100	Heavy Duty	17-1/2" x 28"
A6667103	RP14 and RP18	Envelope	100	Heavy Duty	20-1/2 x 14-1/4"

<b>INSTITUTIONAL PACKAGES</b>					
Description	SG14R, SSH55/55R/55T, SSH60/60R, SE14/14R/14T	SSH75/75R, SSH60W/60WR, SE18/18R	MEGAFRY	FD Filter Drawer	BNB
Door Latch Assembly	Required	Required	Required		Required
16ga. Tank/Front panel cover assembly	Required	Required	Required		Required
Flanged legs	Required	Required	Required		Required
Stainless back	Required	Required	Required		Required
Gas - Total Add-on	N/A	N/A	N/A	See Note 1	N/A
Electric - Total Add-on	N/A	N/A	N/A	See Note 1	N/A

- Locks and keys to be supplied by end user
- Not available with institutional package: Basket Lifts, Filter Flush Hose, Quick Disconnects, Casters, Fat Vat
- NOTE 1: No modifications required for institutional packages on this product
- All exposed fasteners meet or exceed requirements set forth by the American Correctional Food Service association (Std. No. 1, section 1401)

# OPTIONS & ACCESSORIES

<b>TANK COVER CHART</b>		
Model Number	18 Gauge Cover	
<b>Without Basket Lifts</b>		
SSHLV14, SSHLV14T, SELV14, SELV14T	B2101519	
SELV184, SSHLV184	B2101521	
SG14/14R, SGBNB14, SSH55/55T/55R/55TR, SSH60/60R	B2101501	
SGBNB18, SSH75/75R, SSH60W/60WR, VF65	B2101502	
SE14/14X/14R/14T	B2101505	
SE18/18R/184/184R	B2101506	
FBG18	B2101510	
FBG24	B2101511	
SGM24	B2101512	
35C+	B3307401	
45C+	B3307501	
65C+	B2100108	
E35	B2101508	
VF35	B2101518	
SGC	B2010504	
SSPG14	B2103001	
<b>With Basket Lifts</b>		
SSHLV14, SSHLV14T, SELV14, SELV14T	B2101519	
SELV184, SSHLV184	B2101521	
SG14/14R, SSH55/55T/55R/55TR, SSH60/60R	B2101603	
SG18, SSH75/75R, SSH60W/60WR	B2101604	
SE14/14X/14R/14T	B2101605	
SE18/18R/184/184R	B2101606	
SSPE14	B2100422	
SSPG14	B2103002	
<b>CASTERS</b>		
Description	Fryer	Part Number
6" Swivel	Economy	B3901501
9" Swivel	Solstice Supreme, SG, SE, VF35, VF65 & Flatbottom Fryers, Pasta Cookers, Rethermalizers, BNB, ROV Triple and up	B3901504
9" Locking	Reduced Oil Volume Fryers, Solo and Dual	B3902304
10" Rigid Non-locking	Solstice SoloFilters	B3902301
10" Rigid Locking	Solstice SoloFilters	B3902303
11" Swivel	MegaFry	B3901505
<b>SGBNB DUMP STATION</b>		
Standard with 4-5/8" recessed top/screen. Matches dimensions of fryer. Approximate shipping weight 150 pounds.		
Description	Notes	
Bread and Batter Dump Station 14"		
Bread and Batter Dump Station 18"		
PFW-1 Built-in Foodwarmer, 750watt		
PFW-2 Free Standing Foodwarmer, 500watt		
Scooped Pan Liner (in lieu of screen)	No Additional Cost - Specify at Point of Order	
Flat Worktop	Call factory for availability n/c	
Flush Worktop	Call factory for availability n/c	
<b>SPLASHGUARDS</b>		
Mounts on tank side to prevent splashing of oil from one unit to another. Consult factory for other height requirements		
Description		
6"		
8"		
10" (Economy Fryers Only)		
12"		
18"		
<b>WORKSHELVES</b>		
Description		
Call factory for specifications and availability		

# BASKETS & WIRE GOODS

<b>BASKET &amp; WIRE GOODS</b>				
Description	Part Number	Size	Type of Handle(s)	Quantity Per Tank
<b>Pasta Wire Goods</b>				
Small Bulk Basket	B4510202	12 1/4" X 13 1/4" X 9"	Sides	1
Large Bulk Basket	B4512702	16" X 13 1/4" X 10"	Sides	1
Round Basket 4 5/8" Fine Mesh	B4510002	4 1/5 ID	Front	6
Round Basket 4 5/8"	B4510001	4 1/5 ID	Front	6
Round Basket 6 1/4"	B4509901	6 1/4 ID	Front	4
Oblong Basket Stainless	B4509801	15 3/4" X 6" X 7"	Front	2
Individual Serving Baskets w/ rack	B9010006	9 Indiv. Baskets w/rack		1
Individual Serving Basket Only	P6071998	Single 4" X 4" Basket		9
Element Rack - Electric	B7611202			1
Tube Rack - Gas	B4510101			1
<b>Twin Baskets Regular Mesh (Shipped standard with equipment)</b>				
35/45C+S, SG14/14R, SSH55/55R, SE14/R VF35, ROV	P6072145	13 1/4" X 6 1/2" X 5 3/4"D	Front	2
SE14T, SSH55T, 55TR	P6072145	13 1/4" X 6 1/2" X 5 3/4"D	Front	1
65C+, SG18, SE18/18R, SSH75/75R, VF65	P6072184	17 1/4" X 8 1/2" X 5 3/4"D	Front	2
SSH60/60R	A4500306	17 1/4" X 6 1/2" X 5 3/4"D	Front	2
SSH60W/60WR, SE184/184R	A4500305	13 1/4 X 8 1/2" X 5 3/4"D	Front	2
<b>Twin Baskets-Fine Mesh</b>				
35/45C+S, SG14/14R, SSH55/55R, VF35, ROV	P6072146	13 1/4" X 6 1/2" X 5 3/4"D	Front	2
SG14T, SE14T/14TR, SSH55T, 55TR	P6072146	13 1/4" X 6 1/2" X 5 3/4"D	Front	1
65C+, SG18, SE18/18R, SSH75/75R, VF65	P6072188	17 1/4" X 8 1/2" X 5 3/4"D	Front	2
<b>Square/Full Size Basket - Regular Mesh (optional in lieu of twin baskets with standard fryers)</b>				
35/45C+S, SG14/14R, SSH55/55R, SE14/R, VF35	P6072143	13 1/4" X 13 1/2" X 5 3/4"D	Front	1
65C+, SG18, SE18/18R, SSH75/75R, VF65	P6072180	17 1/2" X 16 3/4" X 5 3/4"D	Sides	1
<b>Square/Full Size Basket - Fine Mesh</b>				
35/45C+S, SG14/14R, SSH55/55R, ROV, VF35	P6072144	13 1/4" X 13 1/2" X 5 3/4"D	Front	1
<b>Triple Size Baskets</b>				
45C+S, SG14/14R, SSH55/55R, SE14/R	P6072147	13 1/4" X 4 1/2" X 5 3/4"D	Front	3
65C+, SG18, SE18/18R, SSH75/75R	P6072185	17 1/4" X 5 1/2" X 5 3/4"D	Front	3
SSH60W/60WR, SELV184, SSHLV184, SE184/184R	A4514901	13 1/4" X 5 5/8" X 5 3/8"D	Front	3
<b>Quadruple Size Baskets</b>				
SSH60W/60WR, SELV184, SSHLV184, SE184/184R	P6072147	13 1/4" X 4 1/2" X 5 3/4"D	Front	4
<b>Tank Racks</b>				
35C+, SGC, VF35	PP10434	13 1/2" X 11 1/2"	---	1
65C+, SE18/18R, SSH75/75R	P6073186	17 1/2" X 17 1/2"	---	1
SG14/14R, 45C+, SSH55/55R, SE14/14R, 45C+	A4500601	13 1/2" X 13 1/2"	---	1
SSH55T/55TR	B4511801	13 1/2" X 6"	---	1
SSH60/60R, VF65	A4500604	13 1/2" X 17 1/2"	---	1
SSH60W/60WR	A4500602	17 1/2" X 13 1/2"	---	1
SG18	B4511901	17 1/2" X 17 1/2" Reversible		1
SE14T	B4512401	13 1/2" X 6 3/4"	---	1
SSHLV14	A4500605	12-1/2" x 11-3/4"	---	1
SSHLV14T	B4511802	12-1/2" x 5-3/4"	---	1
SSHLV184	A4500606	12-1/2" x 15-3/4"	---	1

# BASKETS & WIRE GOODS

BASKET & WIRE GOODS				
Description	Part Number	Size	Type of Handle(s)	Quantity- Per Tank
<b>Tank Screen - Mesh</b>				
SG18, SE18/18R, SSH75/75R	P6072186	17-1/2" x 17-1/2"	---	1
SG14/14R, SSH55/55R, SE14/14R	A4500201	13-1/2" x 13-1/2"	---	1
SE14T	B4512501	13-1/2" x 6"	---	1
SGM24	P6072402	23-1/2" x 23-1/2"	---	1
SSH60/60R, VF65, SE184/184R	A4500203	17-1/2" x 13-1/2"	---	1
<b>Drain Screen for Bread and Batter Cabinet (Dump Station)</b>				
SGHLVBNB, SEHLVBNB	B4508109	---	---	---
SGBNB14, SSHBNB14	B4508108	---	---	---
SGBNB18, SSHBNB18	B4508107	---	---	---
SEBNB14	B4508111	---	---	---
SEBNB18	B4508110	---	---	---
<b>Fish Grids</b>				
SG14/14R, SE14/14R, SSH55/55R	B7425301	13-1/2" x 13-1/2"	---	---
SG18, SE18/18R, SSH75/75R	B7425401	17-1/2" x 17-1/2"	---	---
SSH60	A5073001	13-1/2" x 17-1/2"	---	---
SSH60W	A5073101	17-1/2" x 13-1/2"	---	---
<b>Megafry Baskets</b>				
Large Megafry Basket	A4514702	23-1/4" x 10" x 5-3/4"	Front/Back	---
Small Megafry Basket	A4514701	23-1/4" x 5-3/4" x 5-3/4"	Front/Back	---
<b>MEGAFRY OPTIONAL BASKET CONFIGURATION TABLE</b>				
	Basket Size/Quantities			
Model Number	23-1/4" x 5-3/4" x 5-3/4"		23-1/4" x 10" x 5-3/4"	
SGM24	4		0	
SGM24	2		1	
SGM24	0		2	
<b>ROV RACK FRYER ACCESSORIES - (see page 6 for accessories included with fryer)</b>				
Model Number	Part Number			
Rack Holder	B5055702			
Product Rack - 12" x 16" x 1"	B5009201			
Product Basket - 12" x 16" x 2"	B5055201			



P6072145



B4510001



P6072147

# START -UP • EXTENDED WARRANTY

## **START-UP:**

### **We now offer prepaid start-ups!**

- Just \$325 for the first serial number and \$100 for each additional serial number at the same location!
- Purchase on your original equipment order and our ASAPD will:

Complete a performance check

- ✓ Boil out the fryer(s)
- ✓ Fill the unit with oil
- ✓ Calibrate as needed
- ✓ Check for proper installation
- ✓ Check for proper performance

- A Start-up must be emailed to Pitco Service at least 5 business days prior to requiring the service at [techservice@pitco.com](mailto:techservice@pitco.com) or fill out a form online at [www.pitco.com/startup\\_request](http://www.pitco.com/startup_request)
- The Start-up is to be completed prior to the customer using the equipment
- All required utilities and associated supporting equipment such as hoods, drains and fire protection equipment must be in place and operational prior to starting up the equipment
- Start-ups are to be performed during normal business hours. 8AM - 5PM.
- Extended Travel fee may apply outside of major metro areas
- Additional fees may be charged for time during security clearance or after hours if needed

## **EXTENDED WARRANTY:**

### **We now offer extended warranties!**

- Extend your Pitco Factory warranty for a full year! Call your Pitco customer service rep for pricing! United States only



# WARRANTY

## ORIGINAL ECONOMY EQUIPMENT LIMITED WARRANTY

### GENERAL WARRANTY

Pitco Frialator, LLC warrants to the original user of its commercial cooking appliances and related equipment that said appliances and related equipment will be free from defects in material and workmanship under normal use for a period of one (1) year from the date of installation, with appropriate documentation, to a maximum of fifteen (15) months from the date of manufacture, subject to the following additions, exceptions, exclusions and limitations.

### What is covered

This warranty is limited to the repair or replacement at the Company's option, without charge, of any part found to be defective within the warranty period and reasonable expenses incurred for freight and material for the installation of such part; in addition, the Company's obligation shall be limited to reimbursement for normal labor on such parts. Pitco Frialator, LLC agrees to pay the Authorized Service and Parts Distributor, for any labor and material required to repair or replace, at the Company's option, any part which may fail due to defects in material or workmanship during the above general warranty period.

### How to Keep Your Warranty in Force

- Make sure any shipping damages are reported immediately. Damages of this nature are the responsibility of the carrier and must be reported by the receiver.
- Install the unit properly. This is the responsibility of the installer and the procedures are outlined in the manual.
- Do not install it in a home or residence.
- Maintain it properly. This is the responsibility of the user of the appliance and the procedures are outlined in the manual.
- Adjustments, such as calibration, leveling, tightening of fasteners or plumbing or electrical connections normally associated with initial installation. These procedures are outlined in the manual and are NOT covered by warranty.
- If it is damaged due to flood, fire or other acts of God, this is not covered under this warranty.
- Use it for what it is intended. If it is used for a purpose other than for which it was intended or designed, resulting damages are not covered under the warranty.
- Make sure that it has the correct voltage, gas supply and/or good quality water. If a failure is due to poor water quality, harsh chemical action, erratic voltage or gas supplies, these damages are not covered under the warranty.
- Do not materially alter or modify from the condition in which it left the factory.
- Do not obliterate, remove or alter the serial number rating plate.
- Use only Genuine OEM parts from Pitco Frialator, LLC or its Authorized Parts and Service Distributors. Non-OEM parts or repairs made by Non-Authorized Service and Parts Distributors are not covered by the warranty.
- If any other failure occurs which is not attributable to a defect in materials or workmanship, it is not covered.
- Food truck & mobile installations may void warranty. Combustion related issues will not be covered.

This warranty specifically excludes parts which wear or would be replaced under normal usage, including, but not limited to, lamps, fuses, interior or exterior finishes, o-rings, gaskets, wire goods. Filter hoses and wash wands are

# WARRANTY

warrantied for 90 days from installation.

## Limits to the Warranty

Outside the United States of America and Canada, this warranty is limited to the replacement of parts and Pitco Frialator, LLC will not bear any other expense be it labor, mileage, freight or travel.

In the United States of America and Canada, this warranty will cover up to 100 miles and two hours of round trip travel charges. Any excess travel is billable to the location.

If any oral statements have been made regarding the appliance, these statements do not constitute warranties and are not part of the contract of sale. This limited warranty constitutes the complete, final and exclusive statement with regard to warranties.

THIS LIMITED WARRANTY IS EXCLUSIVE AND IS IN LIEU OF ALL OTHER WARRANTIES WHETHER WRITTEN, ORAL OR IMPLIED, INCLUDING, BUT NOT LIMITED TO ANY WARRANTY OF MERCHANTABILITY OR FITNESS FOR A PARTICULAR PURPOSE OR WARRANTY AGAINST LATENT DEFECTS.

## Limitations of Liability

In the event of a warranty or other claim, the sole obligation of Pitco Frialator, LLC will be the repair or replacement, at the Company's option, of the appliance or the component part. This repair or replacement will be at the expense of Pitco Frialator, LLC except as limited by this warranty statement. Any repair or replacement under this warranty does not constitute an extension in time to the original warranty. Parts covered under this warranty will be repaired or replaced, at the Company's option, with new or functionally operative parts. The liability of Pitco Frialator, Inc. on any claim of any kind, including claims based on warranty, express or implied contract, negligence, strict liability or any other legal theories will be exclusively the repair or replacement of the appliance. This liability will not include, and the purchaser specifically renounces any right to recover special, incidental, consequential or other damages of any kind, including, but not limited to, injuries to persons, damage to property, loss of profits or anticipated loss of the use of this appliance.

If any provision of this warranty is unenforceable under the law of any jurisdiction, that provision only will be inapplicable there, and the remainder of the warranty will remain unaffected. The maximum exclusion or limitation allowed by law will be substituted for the unenforceable provision.

## How to Obtain Warranty Service

First direct your claim to the Pitco Frialator, LLC Authorized Service and Parts Distributor, [www.pitco.com/serv.asp](http://www.pitco.com/serv.asp) closest to you giving complete model, serial and code numbers, voltage, gas type, and description of the problem. Proof of the date of installation and/or the sales slip may also be required. If this procedure fails to be satisfactory, write the National Service Manager, Pitco Frialator, LLC, P. O. Box 501, Concord, NH. 03302-0501. USA

This warranty gives you certain specific legal rights; you may have other rights which vary from state to state.

# SALES REPRESENTATIVES

STATE	ZIP CODE	REP
Alabama	.....	7
Alaska	.....	15
Arizona	.....	04
Arkansas	.....	7
California	.....	13
Colorado	.....	04
Connecticut		
	060-063.....	01
	0641-0642.....	01
	0643.....	12
	0644-0648 .....	01
	0649 .....	12
	065, 067.....	01
	066, 068-069.....	12
Delaware	.....	11
District of Columbia	.....	14
Florida		
	324-325.....	7
	All other zip codes..	03
Georgia	.....	7
Hawaii	.....	15
Idaho	.....	15
Illinois		
	600-619.....	09
	620, 622.....	02
	623-628.....	09
	629 .....	02
Indiana		
	463-464.....	09
	All other zip codes..	02
Iowa	.....	08
Kansas	.....	08
Kentucky	.....	02
Louisiana	.....	07
Maine	.....	01
Maryland	.....	14
Massachusetts	.....	01
Michigan	.....	02
Minnesota	.....	23
Mississippi	.....	07
Missouri	.....	08
Montana	.....	15
Nebraska	.....	08
Nevada	.....	13

- 1 C.R. Peterson Associates**  
 355 Bodwell Street Suite A  
 Avon, MA 02322  
 Tel: (508) 238-8821  
 Tel: (800) 257-4040  
 Fax: (508) 238-3647  
 www.crpeterson.com
- 2 Gabriel East Group**  
 601 5th St. NW #400  
 Grand Rapids, MI 49504  
 Tel: (616) 583-9720  
 www.gabrielgrp.com
- 3 Eaton Marketing & Associates**  
 5325 115th Avenue North  
 Clearwater, FL 33760  
 Tel: (727) 531-0899  
 Fax: (727) 531-2906  
 www.eaton-marketing.com
- 4 Hansen Group Rockies**  
 4925 E. 38th Avenue  
 Denver, CO 80207  
 Tel: (303) 750-3727  
 Fax: (303) 750-0052  
 www.thehansengroup.net
- 5 Chrane Foodservice**  
 9155 Sterling St Ste. 140  
 Irving, TX 75063  
 Tel: (844) 925-1239  
 www.chranefs.com
- 6 Griffin Marketing Group**  
 1935 S Main St, Suite 102  
 Salisbury, NC 28144  
 Tel: (704) 603-4556  
 Fax: (704) 603-4561  
 www.griffinreps.com
- 7 Hansen Group**  
 1770 Breckinridge Pkwy  
 Suite 500  
 Duluth, GA 30096  
 Tel: (770) 667-1544  
 www.thehansengroup.net
- 8 Heartland Reps**  
 1053 W. Couchman Drive  
 Kearney, MO 64060  
 Tel: (888) 486-1253  
 www.heartlandreps.com
- 9 The Jay Mark Group**  
 175 Lively Blvd.  
 Elk Grove Village, IL 60007  
 Tel: (847) 545-1918  
 Fax: (847) 545-1932  
 www.jaymark.net
- 10 Link2 Hospitality Solutions**  
 108 Lincoln Parkway  
 East Rochester, NY 14445  
 Tel: (585) 254-1780  
 Fax: (585) 254-2154  
 www.link2hs.com
- 11 One Source**  
 800 Calcon Hook Rd.  
 Sharon Hill, PA 19079  
 Tel: (610) 565-5200  
 Fax: (610) 565-0725  
 www.osreps.com
- 12 CR Peterson South**  
 355 Bodwell St Suite A  
 Avon, MA 02322  
 Tel: (508) 238-8821  
 Tel: (800) 257-4040  
 Fax: (508) 238-3647  
 www.crpeterson.com
- 13 Preferred Foodservice Specialists**  
 20715 Dearborn Street  
 Chatsworth, CA 91311  
 Tel: (818) 998-9292 (South)  
 Tel: (415) 854-6428 (North)  
 www.preferredfs.com
- 14 Schmid Wilson Group**  
 2545 Lord Baltimore Drive, Suite E  
 Windsor Mill, MD 21244  
 Tel: (410) 998-9191  
 www.theswg.com

# SALES REPRESENTATIVES

- 15 RHI Solutions**  
5628 Airport Way S, Ste 250  
Seattle, WA 98108  
Tel: (425) 251-0531  
www.rhi-solutions.com
- 16 Anderson Foodservice Solutions**  
N8W22520 Johnson Dr. Suite K  
Waukesha, WI 53186  
Tel: (262) 436-0102  
www.asfreps.com
- 17 W.D. Colledge**  
3220 Orlando Drive, Unit 3  
Mississauga, Ontario L4V 1R5  
Tel: (905) 677-4428  
Fax: (905) 677-5357  
www.wdcolledge.com
- 18 W.D. Colledge**  
134 Bainbridge Cr  
Edmonton, Alberta T5T 6B4  
Tel: (780) 444-8928  
www.wdcolledge.com
- 19 W.D. Colledge**  
1004 - 151 West 2nd St.  
North Vancouver, BC V7M 3P1  
Tel: (604) 787-0335  
www.wdcolledge.com
- 20 W.D. Colledge**  
23 Bisset Cr  
Winnipeg, MB, R2Y 1B7  
Tel: (604) 999-8579  
www.wdcolledge.com

- 21 W.D. Colledge**  
1422 Purcells Cove Road  
Halifax, Nova Scotia B3P 1B5  
Tel: (902) 456-5175  
www.wdcolledge.com
- 22 W.D. Colledge**  
8586A Lemieux St  
LaSalle, Quebec H8N 2B6  
Tel: (514) 365-3753  
Fax: (514) 365-0761  
www.wdcolledge.com
- 23 Gabriel West Group**  
601 5th St. NW #400  
Grand Rapids, MI 49504  
Tel: (616) 583-9720  
www.gabrielgrp.com

STATE	ZIP CODE .....	REP
New Hampshire.....		01
New Jersey		
	070-079 .....	12
	080-086 .....	11
	087-089 .....	12
New Mexico.....		04
New York		
	063.....	1
	100-119.....	12
	All other zip codes..	10
North Carolina.....		06
North Dakota.....		23
Ohio .....		02
Oklahoma .....		05
Oregon .....		15
Pennsylvania		
	150-165 .....	02
	All other zip codes..	11
Rhode Island.....		01
South Carolina.....		06
South Dakota.....		23
Tennessee.....		07
Texas		
	798-799.....	04
	All other zip codes..	05
Utah .....		04
Vermont .....		01
Virginia .....		14
Washington.....		15
West Virginia.....		02
Wisconsin .....		16
Wyoming		
	834 .....	15
	All other zip codes..	04
<b>CANADA</b>		
Alberta .....		18
British Columbia .....		19
Manitoba.....		20
Newfoundland.....		21
New Brunswick .....		21
Nova Scotia.....		21
Prince Edward Island.....		21
Saskatchewan.....		20
Ontario .....		17
Quebec .....		22

# ORDERING INFORMATION

## ORDERING INFORMATION

### PLEASE PROVIDE THE FOLLOWING INFORMATION:

- Complete Bill To/Ship To address
- Ultimate destination of equipment
- Purchase order number
- Requested ship dates and carrier
- Any special instructions
- Indicate Mark For
- CE approval required

### INFORMATION FOR EQUIPMENT:

- Gas Type (natural or propane)
  - Voltage/Phase
  - Altitude requirements
  - Model number
  - Fryer/Filter line-up
- NOTE: FRYERS NOT AVAILABLE FOR CURB MOUNT

## TERMS AND CONDITIONS

- Prices are LIST PRICES F.O.B factory, Concord, NH and do not include freight charges or installation
- Subject to a 35% fee if cancelled within 48 hours of ship date
- Freight Classification: Class 85
- Prices and specifications are subject to change

## CHANGES

Additional costs incurred due to changes requested within two weeks of scheduled shipping date will be chargeable.

## RETURNS

Prior authorization must be received in order to return merchandise. Please contact Customer Service. Credit will be issued for returned product less initial delivery freight cost. All authorized returns must be freight prepaid and are subject to a 35% restocking charge. All authorized returns will be paid by credit memo. Refurbishing, if necessary, will be an additional charge and will be deducted from any credit that may be allowed. Items not stocked, specially configured or built to order do not qualify for return. Any specials that are authorized for return may be subject for a fee beyond the standard restocking fee. Returns must be received at the assigned return address within sixty (60) days from authorization date. Pitco reserves the right to refuse or charge a 45% restocking fee on equipment returned without prior authorization.

Returned Goods Authorization (RGA) must accompany all returns. All returns must be shipped prepaid within 30 days of authorization and must be in proper crating.

Custom options are non-refundable, non returnable items.

Title passes to the consignee when merchandise is accepted by the carrier and therefore travels at the risk of the purchaser. FOB factory.

## INTERNATIONAL ORDERS

Please contact your Pitco Customer Service Representative for specific details.

CHECK YOUR ORDER STATUS ONLINE

<https://www.pitco.com/order-lookup/>

To speak to a Customer Service Representative call: +1 603.225.6684

Email orders: [orderpitco@pitco.com](mailto:orderpitco@pitco.com)